

10Gb/s XFP Optical Transceiver Module 1310nm 10km LR

Features

- 10Gb/s serial optical interface compliant to 802.3ae
- Uncooled 1310nm DFB transmitter and Pin photodiode receiver
- XFP Mechanical interface with bail latch and hot pluggable
- XFI High Speed Electrical Interface
- 2-wire interface for management and digital diagnostic monitor
- Low Power Consumption, Single +3.3V Power supply
- Operating case temperature: 0 to 70°C
- II-metal housing for superior EMI performance
- Advanced firmware allow customer system encryption information to be stored in transceiver
- RoHS compliant
- No reference clock needed



Applications

- SONET(OC-192)/SDH(STM64) line card
- 10GBASE-LR (10.3125Gbps)
- 10GBASE-LW (9.953Gbps)
- 10GE Ethernet switches and routers
- 10GE Storage

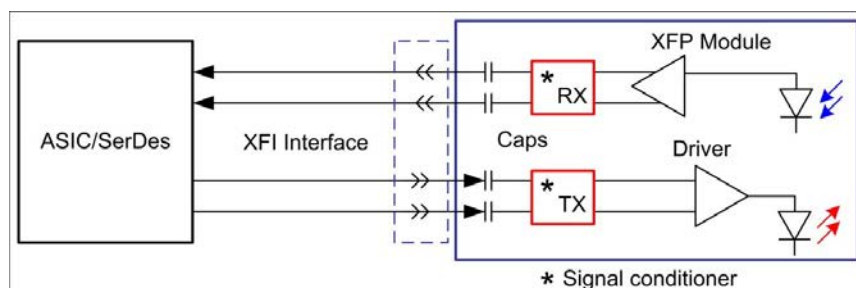

Figure1: Interface to Host

1. General Description

DRN-XF-10GD-LR is a very compact 10Gb/s optical transceiver module for serial optical communication applications at 10Gb/s. DRN-XF-10GD-LR converts a 10Gb/s serial electrical data stream to 10Gb/s optical output signal and a 10Gb/s optical input signal to 10Gb/s serial electrical data streams. The high speed 10Gb/s electrical interface is fully compliant with XFI specification and allows FR4 host PCB trace up to 200mm.

DRN-XF-10GD-LR is designed for use in a variety of 10Gb/s SONET/SDH equipment including FEC (9.95Gb/s to 11.3Gb/s) and Ethernet LAN (10.3Gb/s) and WAN (9.95Gb/s) applications. The high performance uncooled 1310nm DFB-LD transmitter and high sensitivity PIN receiver provide superior performance for SONET /SDH and Ethernet applications at up to 10km links. The fully XFP compliant form factor provides hot pluggability, easy optical port upgrades and low EMI emission.

2. Functional Description

DRN-XF-10GD-LR contains a duplex LC connector for the optical interface and a 30-pin connector for the electrical interface. Chart of section 3 shows the functional block diagram of Transceiver.

Transmitter Operation

The transceiver module receives 10Gb/s electrical data and transmits the data as an optical signal. The transmitter contains a Clock Data Recovery (CDR) circuit that reduces the jitter of received signal and reshapes the electrical signal before the electrical to optical (E-O) conversion. The optical output power is maintained constant by an automatic power control (APC) circuit. The transmitter output can be turned off by TX disable signal, at TX_DIS pin. When TX_DIS is asserted high, the transmitter is turned off.

Receiver Operation

The received optical signal is converted to serial electrical data signal. The optical receiver contains a CDR circuits that reshapes and retimes an electrical signal before sending out to the XFI channel (i.e. XFP connector and high speed signal traces). The RX_LOS signal indicates insufficient optical power for reliable signal reception at the receiver.

Management Interface

A 2-wire interface (SCL, SDA) is used for serial ID, digital diagnostics and other control /monitor functions. The address of XFP transceiver is 1010000x. MOD_DESEL signal can be used in order to support multiple XFP modules on the same 2-wire interface bus. Interface is compliant to XFP MSA.

3. Transceiver Block Diagram

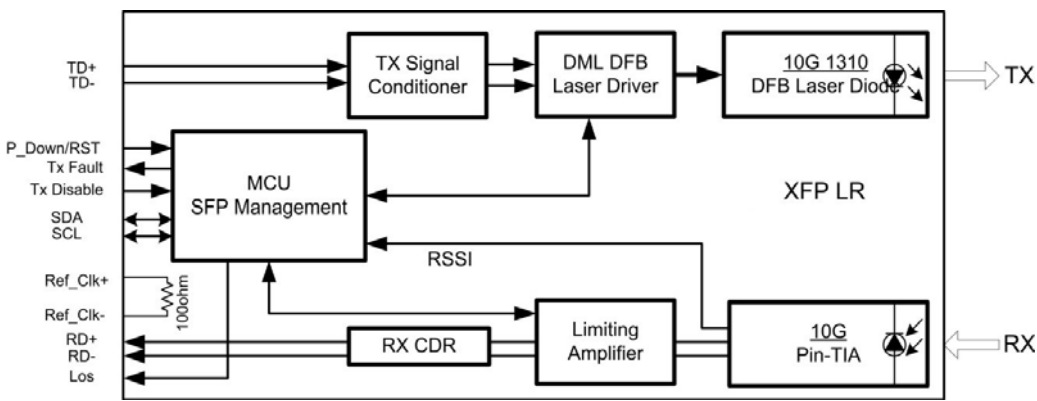

Pin Assignment and Pin Description

XFP Transceiver Electrical Pad Layout

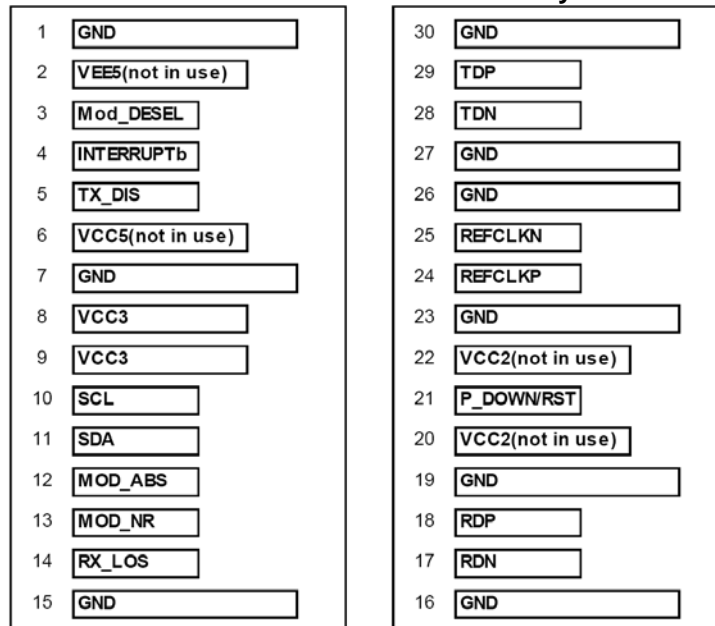

Bottom View

Top View

Pin Descriptions

Pin#	Name	Logic	Description	Note
1	GND		Module Ground	1
2	VEE5		0.2V Power Supply , not in use	3
3	MOD_DESEL	LVTTTL-I	Module De-select; When held Low allows module to respond to 2-wire serial interface	
4	INTERRUPTb	LVTTTL-O	Indicates presence of an important condition, which can be read over the 2-wire serial interface. This pin is an open collector output and must be pulled up to host_Vcc on the	2
5	TX_DIS	LVTTTL-I	Transmitter Disable; When asserted High, transmitter output is turned off. This pin is pulled up to VCC3 in the	
6	VCC5		+5V Power Supply, not in use	3
7	GND		Module Ground	1
8	VCC3		+3.3V Power Supply	
9	VCC3		+3.3V Power Supply	
10	SCL	I/O	2-wire serial interface clock. Host shall resistor connected to host_Vcc of +3.3V.	2
11	SDA	I/O	2-wire serial interface data. Host shall use a pull-up resistor connected to host_Vcc of +3.3V.	2
12	MOD_ABS	LVTTTL-O	Indicates Module is not present. Host shall pull up this pin, and grounded in the module. "High" when the XFP module is absent from a host board	2
13	MOD_NR	LVTTTL-O	Module not ready; When High, Indicates Module Operational Fault. This pin is an open collector and must be pulled to host_Vcc on the host board	2,4,5
14	RX_LOS	LVTTTL-O	Receiver Loss of Signal; When high, indicates insufficient optical input power to the module. This pin is an open collector and must be pulled to host_Vcc on the host board	2
15	GND		Module Ground	
16	GND		Module Ground	
17	RDN	CML-O	Receiver Inverted Data Output; AC coupled inside the module	
18	RDP	CML-O	Receiver Non-Inverted Data Output; AC coupled in side the module	
19	GND		Module Ground	1
20	VCC2		+1.8V Power Supply; not in use	3
21	P_DOWN/RST	LVTTTL-I	Power down; When High, module is limited power mode. Low for normal operation. Reset; The falling edge indicates complete reset of the module. This pin is pulled up to VCC3	
22	VCC2		+1.8V Power Supply; not in use	3
23	GND		Module Ground	1
24	REFCLKP	PECL-I	Reference clock Non-Inverted Input; not in use	
25	REFCLKN	PECL-I	Reference clock Inverted Input; not in use	
26	GND		Module Ground	1
27	GND		Module Ground	1
28	TDN	CML-I	Transmitter Inverted Data Input; AC coupled inside the module	
29	TDP	CML-I	Transmitter Non-Inverted Data Input; AC coupled inside the module	
30	GND		Module Ground	1

Notes:

1. Module ground pins are isolated from the module case and chassis ground within the module.
2. Shall be pulled up with 4.7k to 10k ohm to a voltage between 3.15V and 3.45V on the host board.
3. Not connected internally.
4. Response time: typ. 20msec (XFP MSA Rev. 4.5 \cong 1msec)
5. MOD_NR = (TX LOL) OR (RX LOL).

Recommended Power Supply Filter

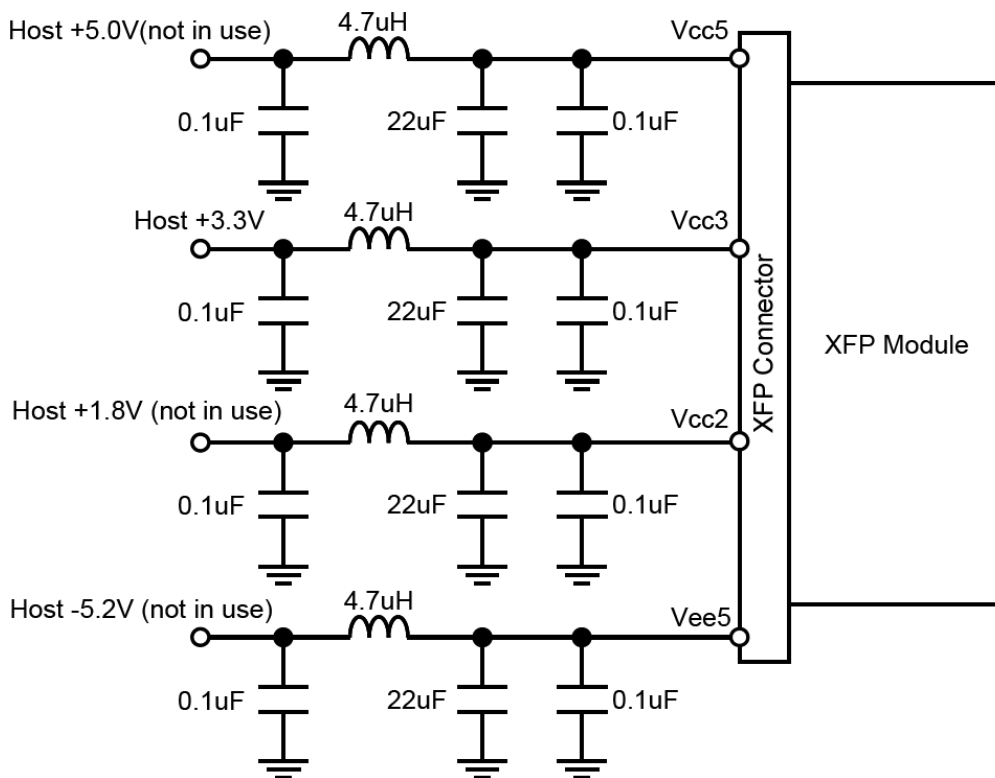

Recommended Electrical Interface to Host

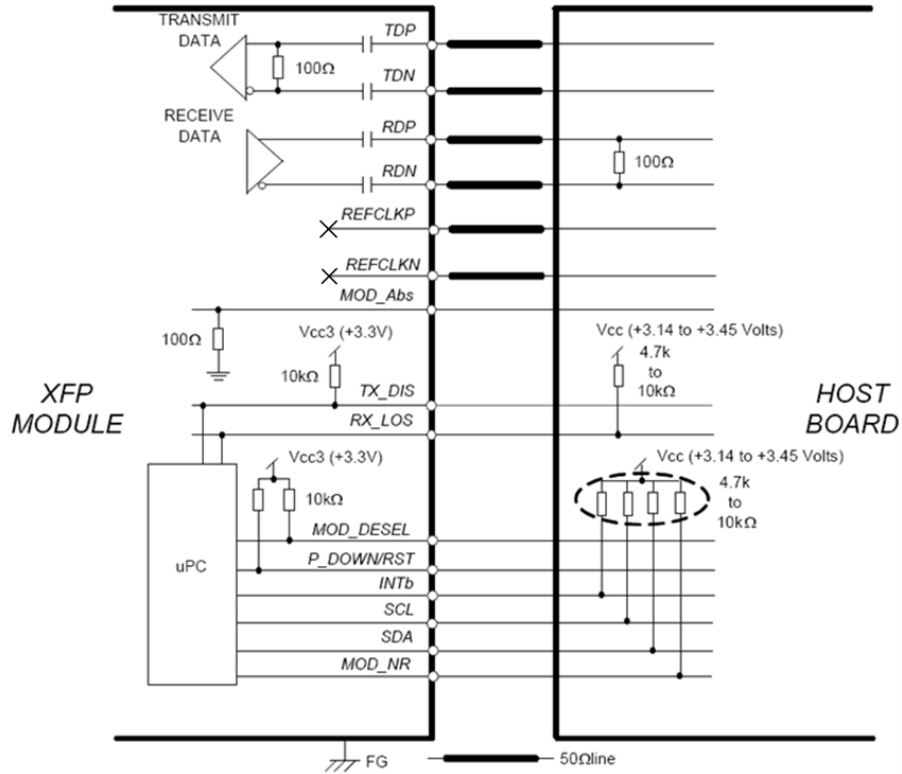

4. Absolute Maximum Ratings

Parameter	Symbol	Min	Max	Unit	Note
Storage Temperature	Tst	-40	85	degC	
Relative Humidity (non-condensation)	RH	-	85	%	
Supply Voltage	VCC3	-0.5	3.6	V	
Voltage on LVTTTL Input	Vilvttl	-0.5	VCC3+0.5	V	
LVTTTL Output Current	Iolvttl	-	15	mA	
Voltage on Open Collector Output	Voco	0	6	V	
Receiver Input Optical Power(Average)	Mip	-	3	dBm	2

Notes:

1. Ta: -10 to 60degC with 1.5m/s airflow with an additional heat sink.
2. Pin Receiver.

5. Recommended Operating Conditions and Supply Requirements

Parameter	Symbol	Min	Max	Unit
Operating Case Temperature(V00)	Topc	-40	85	degC
Relative Humidity (non-condensing)	Rhop	-	85	%
Power Supply Voltage	VCC3	3.135	3.465	V
Power Supply Current	ICC3	-	500	mA
Total Power Consumption	Pd	-	1.8	W

6. Low Speed Control and Alarm Signals Electrical Interface

Parameter	Symbol	Min	Max	Units	Note
XFP Interrupt, Mod_NR, RX_LOS	V _{ol}	0.0	0.4	V	1
	V _{oh}	V _{cc} -0.5	V _{cc} +0.3		2
XFP TX_DIS, P_DOWN/RST	V _{il}	-0.3	0.8	V	3
	V _{ih}	2.0	VCC3+0.3		4
XFP SCL and SDA Output	V _{ol}	0.0	0.4	V	1
	V _{oh}	V _{cc} -0.5	V _{cc} +0.3		2
XFP SCL and SDA Input	V _{il}	-0.3	VCC3*0.3	V	5
	V _{ih}	VCC3*0.7	VCC3+0.5		6
Capacitance for XFP SCL and SDA I/O pin	C _i	-	14	pF	
Total bus capacitive load for SCL and SDA	C _b	-	100	pF	7
			400	pF	8

Notes:

1. Pull-up resistor must be connected to host_Vcc on the host board. I_{ol}(max)=3mA
2. Pull-up resistor must be connected to host_Vcc on the host board.
3. Pull-up resistor connected to VCC3 within XFP module. I_{il}(max)= -10μA.
4. Pull-up resistor connected to VCC3 within XFP module. I_{ih}(max)= 10μA.
5. Pull-up resistor must be connected to host_Vcc on the host board. I_{ol}(max)= -10μA.
6. Pull-up resistor must be connected to host_Vcc on the host board. I_{ol}(max)= 10μA.
7. At 400KHz, 3.0kohms pull-up resistor, at 100kHz 8.0kohms pull-up resistor max.
8. At 400KHz, 0.8kohms pull-up resistor, at 100kHz 2.0kohms pull-up resistor max.

7. Optical Interface

Transmitter Optical Interface						
Parameter	Symbol	Min	Typical	Max	Unit	Note
Operating Data Rate	-	9.95		11.30	Gb/s	1
Output Center Wavelength	l _{tc}	1290	1310	1330	nm	
Spectral Width	d _l	-		1	nm	
SMSR	SMSR	30		-	dB	
Average Output Power	P _o	-6		-1	dBm	2
Disabled Power	P _{off}	-		-30	dBm	2
Extinction Ratio	ER	6		-	dB	2
Minimum OMA-TDP (10G Ethernet)	OMAt _{dp}	-5.2		-	dBm	3
Eve Mask 1 (SONET/SDH)		GR-253-CORE/ITU-T G.691				2
Eve Mask 2 (10G Ethernet)		IEEE802.3ae				3
Generation Jitter 1 (20kHz - 80MHz)				0.15	Ulp-p	2.4
Generation Jitter 2 (4MHz - 80MHz)				0.1	Ulp-p	2.4
RIN	RIN	-		-128	dB/Hz	
Optical Path						
Parameter	Symbol	Min	Typical	Max	Unit	Note
Chromatic Dispersion (SONET/SDH)	CD	-		6.6	ps/nm	
Operating Distance (10G Ethernet)				10	km	
Attenuation (SONET/SDH)		0		4	dB	
Channel Insertion Loss (10G Ethernet)		0		6	dB	
Maximum DGD (SONET/SDH)	DGD	-		30	ps	
Receiver Optical Interface						
Parameter	Symbol	Min	Typical	Max	Unit	Note
Operating Data Rate	-	9.95		11.30	Gb/s	1
Input Center Wavelength	l _{rc}	1260		1565	nm	
Overload	R _{ovl}	0.5		-	dBm	
Minimum Sensitivity	P _{min}	-	-18	-14.6	dBm	2
Sensitivity in OMA	OMA ₀	-		-12.6	dBm	3
Stressed Sensitivity in OMA	OMA _{st}	-		-10.3	dBm	3
RX LOS Assert Level	RLOS _a	-25			dBm	
RX LOS Deassert Level	RLOS _d			-15	dBm	
RX LOS Hysteresis	RLOS _h	1		5	dB	
Optical Path Penalty	PN	-		1	dB	1
Optical Return Loss	ORL	14		-	dB	
Jitter Tolerance	JTL	GR-253-CORE/ITU-T G.783				

Notes:

1. Data rate tolerance 10GBASE-LR/LW: typ. +/-100ppm
2. Measured at 10.3125Gbps, Non-framed PRBS2³¹-1, NRZ
3. Measured by using XFP evaluation board.

8. Digital Diagnostic Functions

The following digital diagnostic characteristics are defined over the Recommended Operating Environment unless otherwise specified. It is compliant to SFF8472 Rev9.2 with internal calibration mode. For external calibration mode please contact our sales staff.

Parameter	Symbol	Min.	Max	Unit	Notes
Temperature monitor absolute error	DMI_Temp	-3	3	degC	Over operating temp
Laser power monitor absolute error	DMI_TX	-3	3	dB	
RX power monitor absolute error	DMI_RX	-3	3	dB	-1dBm to -15dBm range
Supply voltage monitor absolute error	DMI_VCC	-0.08	0.08	V	Full operating range
Bias current monitor	DMI_Ibias	-10%	10%	mA	

9. Mechanical Dimensions

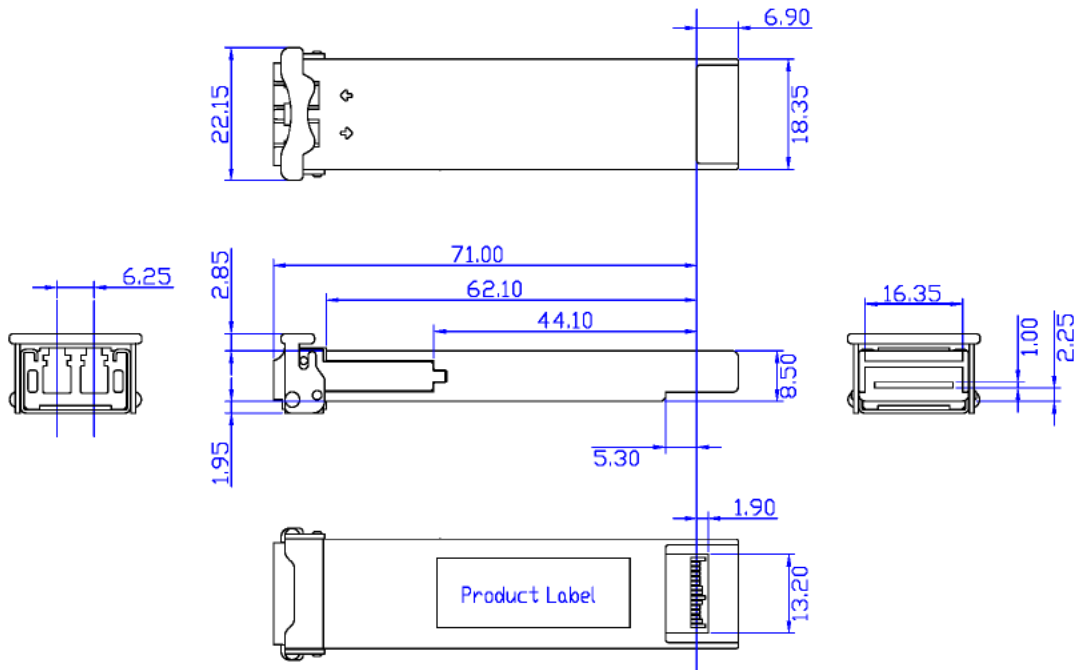

10. MSA Compliant EEPROM Structure

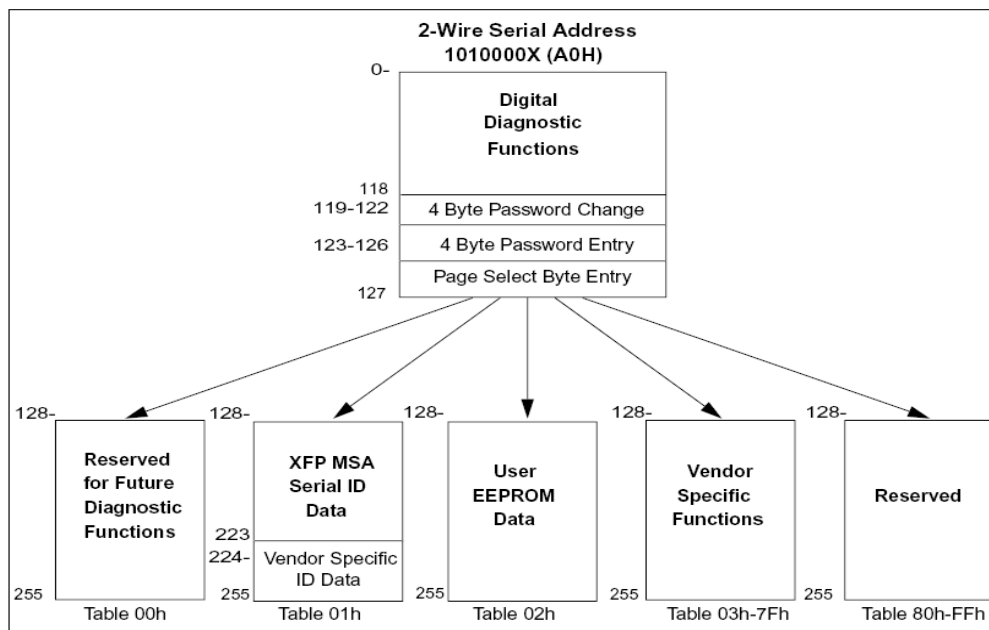

11. ESD

This transceiver is specified as ESD threshold 2kV for all electrical input pins, tested per MIL-STD-883, Method 3015.4 /JESD22-A114-A (HBM). However, normal ESD precautions are still required during the handling of this module. This transceiver is shipped in ESD protective packaging. It should be removed from the packaging and handled only in an ESD protected environment.

12. Laser Safety

This is a Class 1 Laser Product according to IEC 60825-1:1993:+A1:1997+A2:2001. This product complies with 21 CFR 1040.10 and 1040.11 except for deviations pursuant to Laser Notice No. 50, dated (July 26, 2001)

13. Ordering information

Part Number	Product Description
DRN-XF-10GD-LR	10Gbps, XFP 1310nm 10km, -5°C ~ +70°C

DRN TEKNOLOJİ reserves the right to make changes to the product(s) or information contained herein without notice. No liability is assumed as a result of their use or application. No rights under any patent accompany the sale of any such product(s) or information. Edition: Jan. 2016 Copyright © DRN TEKNOLOJİ BİLİŞİM SİSTEMLERİ SAN. VE DİŞ TİC. LTD. ŞTİ. All Rights Reserved.

E-mail: info@drnteknoloji.com

Web : <http://www.drnteknoloji.com>